

Setting New Standards for Ultra High Performance HVAC



What if you could guarantee that your commercial HVAC system would operate as efficiently in 10 years as it did on the day it was commissioned? What if you could dramatically reduce energy and maintenance costs? How exactly would a solution accomplish these feats? Just how great could the benefits be?

This paper explores the common challenges of maintaining the performance of today's complex HVAC systems and the benefits and limitations of current methodologies for improving energy performance. The paper will also introduce you to new, enterprise application approaches to ongoing plant management that are transforming the way

commercial HVAC systems are operated and maintained. Just as businesses have improved business processes, productivity and profitability through the use of enterprise applications, facilities that have taken advantage of these networked technologies are realizing significant, persistent energy reductions that are not possible with conventional approaches to plant control and management.

With networked controls, building owners and operators are able to meet three main operational goals: improving occupant comfort, reducing energy usage, and sustaining high levels of energy savings year after year. These enterprise applications are setting new standards for Ultra High Performance HVAC.

Persistence: The Missing Link in Commercial HVAC Energy Efficiency

Even though HVAC typically constitutes 40% of a commercial building's total energy usage, energy efficiency is a relatively new consideration for commercial HVAC design. Achieving HVAC energy reduction is rapidly becoming a priority, however, with rising energy prices, and as commercial building owners search for ways to be more competitive, satisfy "green" corporate social responsibility objectives and meet new government mandates for higher levels of energy efficiency.

Energy efficient HVAC is not simple to achieve or sustain. Even new "state of the art" commercial HVAC systems lose operational efficiency after installation because of the way they are designed, installed and maintained. Traditionally, HVAC systems are considered as a set of discrete pieces of mechanical equipment. Each pump, chiller, tower and air handling unit is designed to be turned on, run at a fixed speed and turned off. In this scenario, equipment components are designed to operate efficiently in isolation, and building automation systems (BAS) control the equipment by turning it on and off automatically. Operating data that resides in the BAS typically is not easily accessible by building operators. If operating data is available, it's usually in the form of unformatted streams of data points – a format not conducive for performance measurement or problem diagnosis.

In recent years, the commercial HVAC industry has begun to take advantage of innovations in electrical equipment such as variable frequency drives (VFDs). By using VFDs, it is possible to vary the speeds of rotating plant equipment (e.g., fans

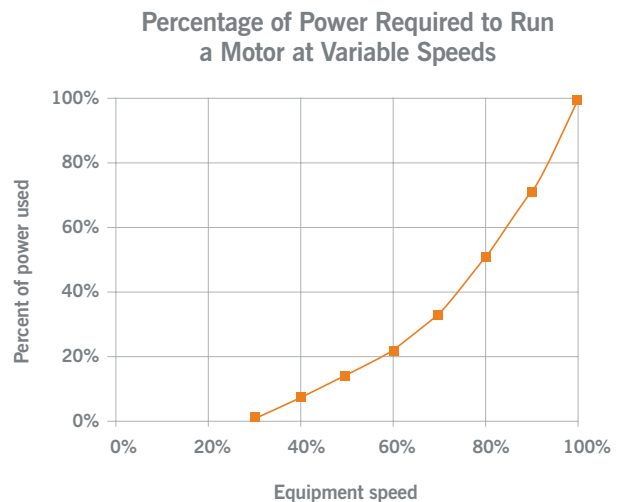

Figure 1: Percentage of power required to run a motor at variable speeds. Running equipment below full load saves energy because power consumption drops proportional to the cube of the motor speed. As an example of this, reducing the speed of an electric motor by one-third reduces its power consumption by 70 percent.

and pumps) and capture the exponential savings that comes from running plant equipment at partial loads (see Figure 1). Additionally, innovations in control methods have made it possible to optimize all of the equipment in an HVAC system by networking the equipment together and intelligently matching air temperature requirements with equipment speeds.

Unfortunately, even optimized plants often fail to maintain their promised efficiency over time. This happens because traditional methods of plant operation and maintenance are based on an outmoded static operating model that treats the plant as a series of mechanical equipment rather than a networked, interrelated system. This is much like treating the human body as a collection of

organs rather than a single entity composed of many interdependent biological systems. Not surprisingly, these outdated methods are not able to attain or maintain high levels of efficiency.

Today, HVAC systems must do more than provide a comfortable environment for a facility's occupants. They must also:

- Attain the highest levels of energy efficiency to reduce operating expenses, thus improving profitability and competitiveness for the building owner.
- Sustain energy reduction levels to ensure savings over time and prevent performance drift.

This whitepaper provides an overview of how advanced control methodologies and networked-based tools are leading to a paradigm shift in the way commercial HVAC systems are operated and managed. As a result, facilities employing these advanced technologies are realizing levels of energy reduction not previously possible, and sustaining those savings over the long-term – creating a new performance standard.

The Problem of Drift and Conventional Solutions

A commonly acknowledged fact about commercial buildings is the difficulty maintaining HVAC systems so that energy performance is sustained. While commercial HVAC systems generally are well-engineered to meet the specific needs of a particular site, their complexity and custom design lends itself to “drift,” or the degradation in performance over time as a result of changes and malfunctions in mechanical and control systems (see Figure 2). Even in the best maintained plants, operational deficiencies may go undetected for long periods of time, negatively impacting energy efficiency.

To remedy this problem, the HVAC industry has evolved various approaches to optimize HVAC system performance. The most widely recognized

Figure 2: Ten Typical Causes of HVAC System Performance Drift*

- Variable frequency drive functionality disabled
- Time clocks not used or circumvented
- Simultaneous heating & cooling
- Duct or valve leakage
- Pumps, fans, actuators or dampers malfunctioning
- Airflow not balanced
- Scheduling & resets do not match specs or actual building usage requirements
- Software programming errors
- Improper controls hardware installation, failure or degradation
- HVAC system not right-sized for facility

* Lawrence Berkeley National Lab; Monitoring Based Commissioning: Benchmarking Analysis of 24 UC/CSU/IOU Projects; June 2009

approach is the practice of “commissioning,” a process that includes an assessment of the HVAC system, identification and correction of mechanical and control issues, and development of new operating procedures. In addition, commissioning is often the time when new energy efficiency strategies are implemented.

One such efficiency strategy is the use of variable speed equipment and custom-developed control methodologies. While some level of savings is usually achieved with this approach, there is risk involved in custom-engineered solutions. Solutions designed uniquely for a specific site are unproven, can take weeks or months to program, and require hands-on functional testing to verify the system is working as designed. In addition, without real-time measurement and verification, it is difficult to verify that predicted energy savings are realized or can be sustained over time. Because of these deficiencies, utility providers are historically and justifiably suspicious of these

custom “software” solutions. As a result, utilities often require some means of measuring and verifying plant efficiency at a point in time. These utility audits are sometimes repeated to determine that a plant is meeting targeted efficiency goals.

There is no question that commissioning can provide a good outcome in the short term, with building operating efficiency improvements typically in the range of 5% to 20%. Because commissioning is focused on improving efficiency at a single point in time, however, commissioned plants – even when maintained at the highest standards – are subject to drift until they are once again recommissioned.

The Savings Opportunity

Building operators who are able to consistently maintain their HVAC systems and mitigate performance drift have the opportunity to predictably and reliably reduce their operating costs over the long term. This is vitally important in today’s competitive

environment and to ensure that investments in energy reduction projects achieve the expected return on investment. In recognition of this fact, the U.S. Green Building Council, the organization that administers the Leadership in Energy and Environmental Design (LEED®) green building certification system, announced the 2009 Building Performance Initiative. The initiative is a comprehensive data collection effort for all LEED certified buildings that is designed to give building operators periodic feedback (e.g., monthly) about energy use that can be used to address performance gaps.

While commissioning has been considered a best practice to date, the availability of enterprise applications that utilize networked software solutions – providing real-time measurement, verification and management of HVAC operating performance – now make it possible for building operators to not only increase the efficiency of their HVAC systems, but to ensure those savings persist month after month, year after year (see Figure 3).

Commercial HVAC System Performance Chart

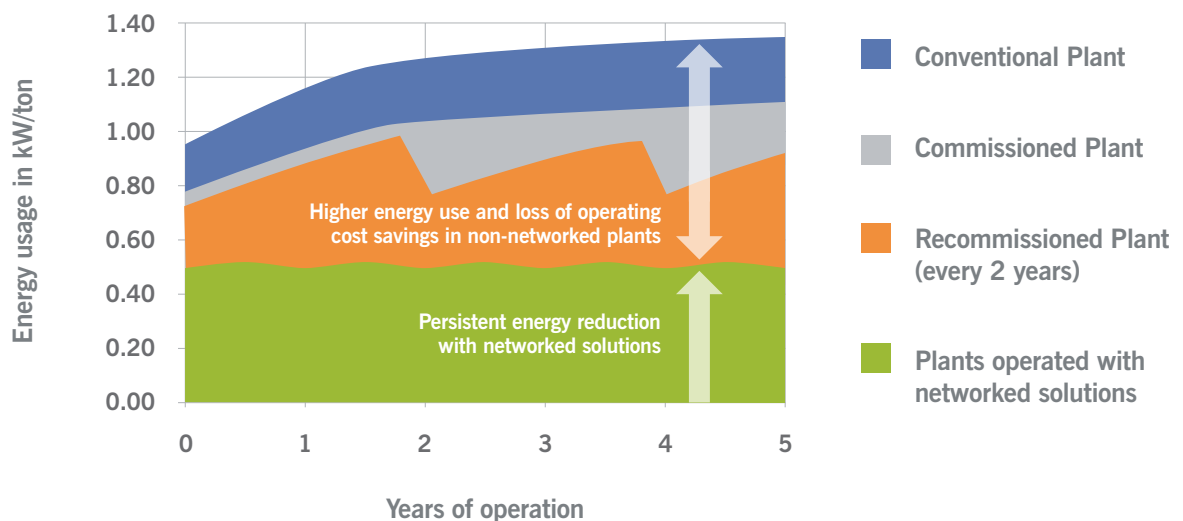

Figure 3: Commercial HVAC System Operating Efficiency. This chart compares plant performance using conventional control and maintenance processes versus plants that have been commissioned or recommissioned, and plants that use networked software solutions. Conventional plants and commissioned plants are subject to performance drift. Plants operated with networked software solutions have the real-time measurement, verification and management data needed to quickly detect, diagnose and repair system faults to ensure persistent energy reductions and operating cost savings.

Chiller Plant Efficiency Scale

Average annual chiller plant efficiency in kW/ton. Just like miles per gallon (MPG), the lower the kW/ton value, the better the energy performance. Input includes: chillers, tower fans, condenser and chilled water pumping.

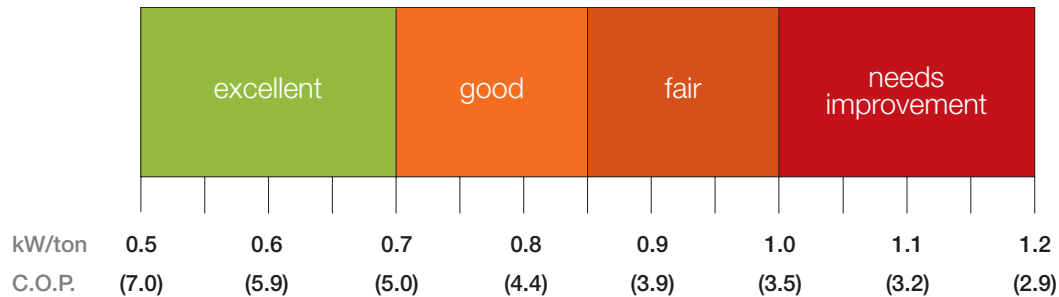

Figure 4: Ultra High Performance HVAC. Research has shown that plants operating for more than a few years typically have an annual wire-to-water operating range of 0.9 to 1.2 kW/ton. Variable speed plants that have undergone commissioning run more efficiently, often in the 0.7 to 0.8 kW/ton range. Ultra High Performance HVAC plants often achieve an average 0.5 kW/ton or less.

HVAC systems that are able to provide occupant comfort as well as demonstrable and persistent annual wire-to-water energy efficiency in the range of 0.4 to 0.6 kW/ton (see Figure 4) will have attained a new standard system performance. We call this Ultra High Performance HVAC.

Networked Software Solutions: The Low Risk/High Reward Approach

Today, building owners and operators are reducing commercial HVAC energy consumption by 30% to 60% by deploying networked applications that combine advanced control methodologies and Web-based measurement, verification and management services. The Mineta San José Airport, for example, reduced HVAC energy use by more than 1.25M kWh in 12 months – a 51% reduction in energy use.

To achieve these results, the San Jose Airport implemented OptimumHVAC software solutions from Optimum Energy. The OptimumHVAC solution includes two control software components that automatically and continuously optimize the

operating efficiency of the entire HVAC system based on real-time building loads: OptimumLOOP™ for chilled water plants and OptimumTRAV™ for variable air volume systems. These two control components enable building owners to achieve the goals of occupant comfort and highly energy efficient HVAC performance.

Achieving the goal of persistent performance that is impervious to drift, however, requires continuous measurement, verification and management (MVM) techniques that enable immediate and precise maintenance of the HVAC system. OptimumMVM™, the third component of OptimumHVAC, makes available the real-time HVAC system performance data that is critical to ensuring energy efficiency – and the resulting operating cost reductions – persist year-after-year. For example, the use of OptimumMVM helped the San Jose Airport maintain a monthly wire-to-water average range of 0.61 to 0.65 kW/ton in the first year of operation, a more than 50% reduction in energy use. The plant is still operating at these levels today.

Save Energy with OptimumLOOP & OptimumTRAV Software

OptimumLOOP and OptimumTRAV use patented, relational-control algorithms to holistically optimize all the equipment within an all-variable flow HVAC system (chillers, fans, pumps, etc.) so they use the least amount of power required to maintain occupant comfort levels. Control set points are automatically calculated every 30 seconds based on real-time building load information inputs received from the building automation system (BAS).

OptimumLOOP and OptimumTRAV control software resides on an industry standard controller that is networked with the BAS using standard communication protocols, making it compatible with virtually any make and model of BAS and plant equipment. Unlike custom-engineered solutions that are programmed directly into the BAS, OptimumHVAC's proven and tested software integrates with existing controls. With this method of delivery, implementation is fast and straightforward, and savings begin immediately.

OptimumMVM: Guaranteeing Persistent Results

As a Web-based measurement, verification and management service, OptimumMVM acts as a continuous feedback loop that provides detailed real-time and historical performance data so operators can quickly detect, diagnose and resolve HVAC system faults. In combination with OptimumLOOP and OptimumTRAV control software, the online OptimumMVM service helps prevent system performance degradation and guarantees long-term savings.

At the core of OptimumMVM is its performance database, which consists of HVAC equipment data points (typically hundreds of points per system) that are captured by the OptimumHVAC controller that resides at the facility, and transmitted via virtual private network connections to Optimum Energy's secure servers. This data is stored both in a real-time database used for the at-a-glance dashboard, as well as in a reporting database that provides historical measurement and verification reporting, and analysis capabilities.

OptimumMVM data is used in a variety of ways to ensure energy reductions are persistent and to streamline plant maintenance and operations. For instance, OptimumMVM automatically generates supervisory level alarms that inform both building operators and Optimum Energy's technicians when an exception condition is negatively impacting energy efficient operation of the HVAC system. Detailed equipment trend data is accessible in easy-to-read charts and graphs, enabling fast diagnosis of system faults that are causing inefficient performance – even though hardware alarms may not have been triggered and overall performance of the plant may not have been noticeably impaired. As these performance issues are being investigated, OptimumMVM's detailed trend data also makes it possible to troubleshoot without a physical inspection of the plant.

As a result of having instant feedback about plant operations, the plant's day-to-day operating processes and procedures are simplified and streamlined. In conventionally operated plants, it is often assumed that the plant is performing to specification. Unless the building undergoes commissioning or recommissioning, however, this assumption is never verified. System faults may go undetected for long periods of time, until scheduled maintenance or occupant complaints uncover hidden problems.

Networked software solutions such as OptimumMVM take the guesswork out of HVAC operations (see Figure 5). By displaying plant efficiency graphically, OptimumMVM puts control into the hands of the building operator, giving them the performance data needed to continuously “commission” the building for optimal energy performance. With the reporting and analysis capabilities of OptimumMVM, building owners no longer have to rely on physical plant inspections or extensive functional testing to detect and diagnose system faults.

With OptimumMVM, data is available in a variety of standard graphs and charts that provide summary information about plant performance, and point-specific trend data that can be used for analysis of a particular event. Custom charts can also be created to focus on a particular data point or event, furthering the ability to analyze and troubleshoot performance issues. As a password-protected Web-based service, designated personnel have 24/7 access to performance data from anywhere they have access to the Internet. This means plant operators can easily share data with maintenance contractors for fast and effective resolution.

Plant Operators: How do we...?	Conventional Plants Operated Without OptimumMVM	Plants Operated with OptimumHVAC and Using OptimumMVM
How do we know our HVAC system is working?	<ul style="list-style-type: none"> Without real-time feedback, daily plant efficiency is unknown. Feedback is only available with monthly utility bills. No simple way to inform facilities manager, financial manager and building owner of performance issues. 	<ul style="list-style-type: none"> Real-time dashboard provides 24/7 verification of plant performance. If plant is performing inefficiently, alarms are automatically generated and sent to building staff, and exceptions logged. Monthly efficiency reports make it easy to share system performance data with all concerned parties.
How do we know if plant maintenance affects optimization?	<ul style="list-style-type: none"> Without real-time and trend data, before and after plant efficiency is unknown. 	<ul style="list-style-type: none"> Real-time displays show current status of all equipment. Trend reports enable before vs. after maintenance comparison for any piece of equipment.
How do we diagnose and fix problems?	<ul style="list-style-type: none"> Consult mechanical and controls contractor. Physically observe plant operation until problem is identified. 	<ul style="list-style-type: none"> Contact Optimum Energy. Optimum Energy's technical staff identifies problem using trend data and knowledge of plant operation. Once problem is identified, Optimum Energy coordinates repair with appropriate contractors.
How do we get measurement and verification data for utility incentives?	<ul style="list-style-type: none"> Hire a measurement and verification (M&V) contractor to install data collection equipment (data loggers, power meters, etc.) and collect data. Analyze and report data per utility requirements. This method does not support ongoing M&V requirements for incentives. 	<ul style="list-style-type: none"> Click on the M&V button on the OptimumMVM dashboard and receive a report via email.
How do we ensure our plant is still running efficiently in a year, or in several years?	<ul style="list-style-type: none"> Hire a commissioning contractor to do a survey and analyze plant performance. Bring in mechanical and controls contractors to resolve accumulated issues. Have modifications verified by the commissioning agent. 	<ul style="list-style-type: none"> With continuous feedback from OptimumMVM, performance issues are identified and resolved as they occur. The OptimumMVM DashBoard verifies plant efficiency daily, on-demand. OptimumMVM documents efficiency each month and annually via reports.

Figure 5: HVAC System Maintenance Procedures without/with OptimumMVM demonstrate how networked solutions change day-to-day operating processes for commercial HVAC.

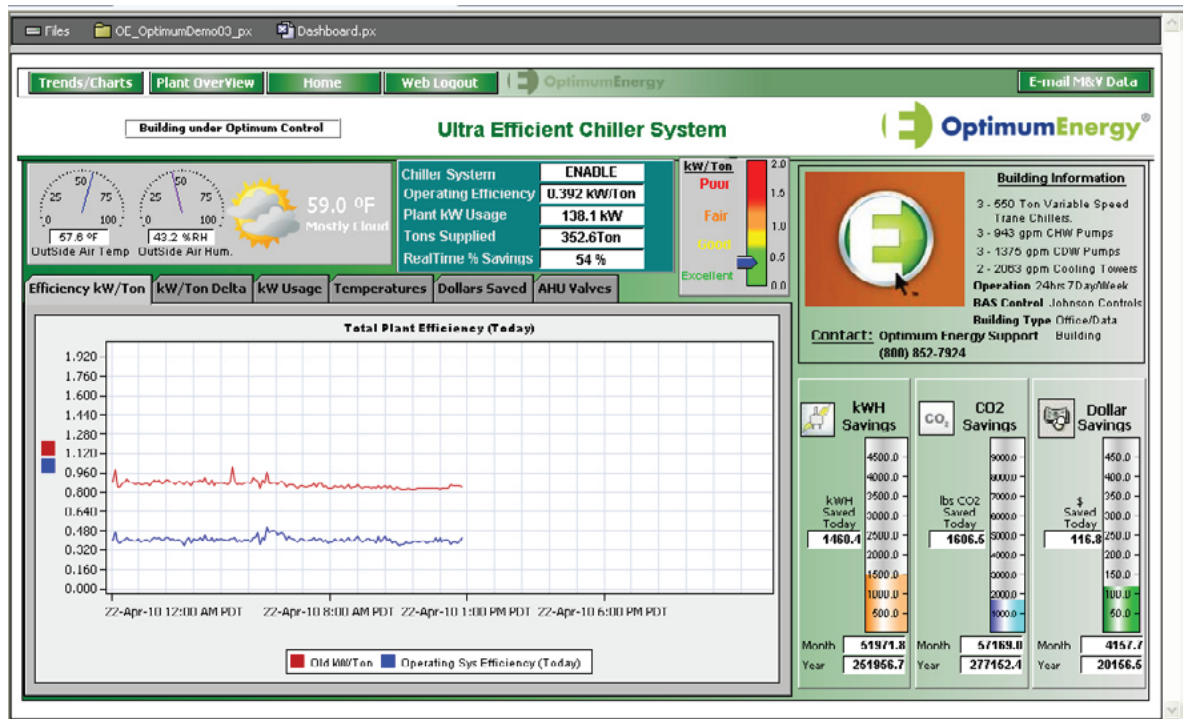

Figure 6: The OptimumMVM DashBoard view provides an at-a-glance overview of plant performance, including real time operating efficiency, daily and monthly dollars saved, and CO₂ reduction.

OptimumMVM data reporting features include:

The Dashboard is a summary screen that displays current plant operation and energy savings (see Figure 6). The Dashboard provides at-a-glance performance checks for the operations team and a quick reference for building owners or investors interested in energy efficiency statistics, including kWh, cost and carbon reductions by the day, month or year, current kW/ton performance and real-time energy savings.

The Plant OverView is a graphical display of real-time plant operation (see Figure 7). The Plant OverView enables building operators to see exactly which system components (e.g., chillers, pumps, tower fans, and air handling and VAV units) are enabled, as well as equipment speeds, kW usage, supply and return chilled water temperatures and other equipment-specific operating parameters. By showing all the essential plant components in one

view, building operators gain a real-time overview of what each piece of equipment is doing in relation to total system operation, and can quickly determine if the plant is operating at peak efficiency or detect faults that are negatively impacting performance.

Trends/Charts provide access to historical performance information for all plant equipment data points captured by the system. Using Trends/Charts, operators can view and analyze specific events and information vital to diagnosing system faults causing poor energy performance. Data is accessible via pre-defined views (see Figure 8), or custom graphs for analysis of specific data points. Moreover, the trend data captured in OptimumMVM is useful for predictive maintenance and troubleshooting equipment and/or controls problems within the plant.

Plant Efficiency Reports, generated monthly and annually by Optimum Energy, provide verification

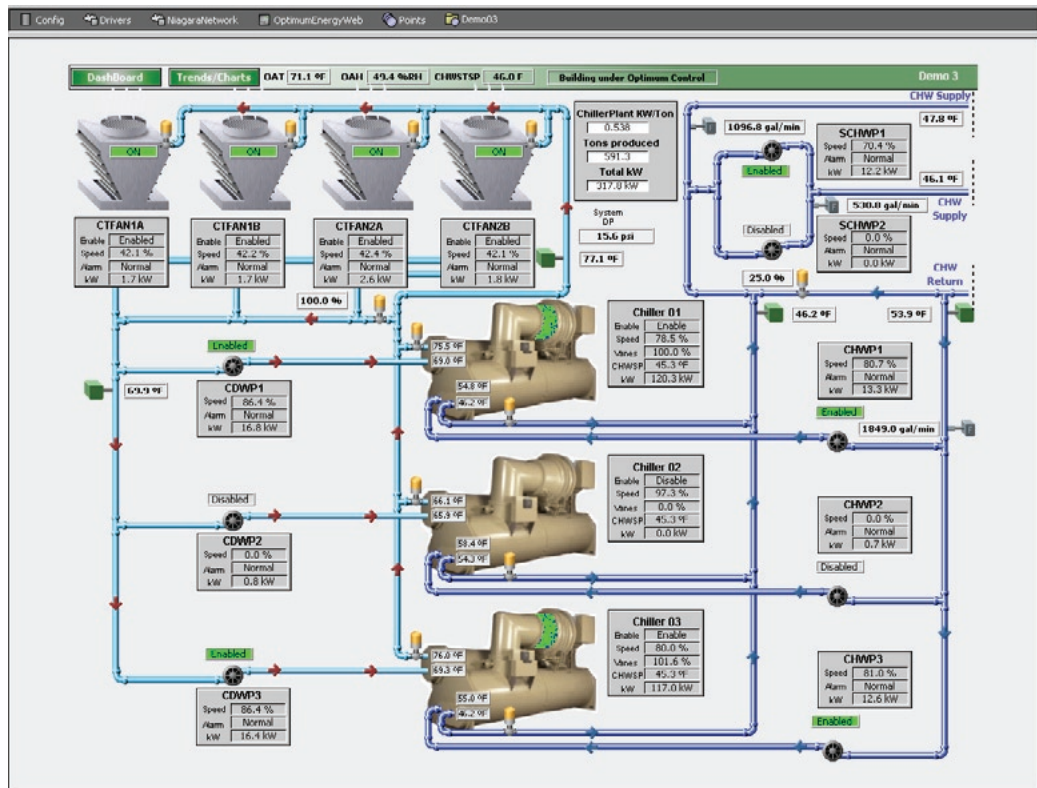

Figure 7: The OptimumMVM Plant OverView display gives building operators a comprehensive look at the operation of HVAC system components.

of efficiency performance over a specific period of time. Plant efficiency reports summarize performance, provide graphical representation of key operating statistics (see Figure 9) and include a summary of any plant issues that are negatively impacting efficiency and need to be resolved.

Conclusion: The New Standard for Ultra High Performance HVAC

In the face of rising energy costs and increased pressure from customers and government mandates to be “green,” it is no longer enough to focus solely on occupant comfort. Today, building owners looking to maximize their investments must consider energy efficiency and persistent HVAC performance.

While custom engineered efficiency solutions and commissioning can result in energy savings, they are expensive and carry some inherent risk as custom solutions. Just as importantly, these traditional methods do not leverage the data that

is available via the BAS to sustain high levels of energy reduction over the long term.

Achieving the best efficiency that persists day-after-day, year-after-year, requires a new approach to HVAC system design, control and operation. The conventional BAS, which primarily is used as a device controller, is also a clearinghouse for valuable HVAC system operating and building load information. Until recently, however, BAS data was largely untapped. Today, by applying networked enterprise applications to commercial HVAC systems, it is possible to more optimally control the HVAC system for maximum energy reductions using standardized software, and fundamentally change the way buildings are managed and maintained.

By leveraging the ability to share information in real-time over the Web, building operators now have access to the data they need to sustain high levels of performance over time. With real-time system performance modeling, building operators



Figure 8: The OptimumMVM Chilled Water Trend Chart is one of a dozen pre-defined views.

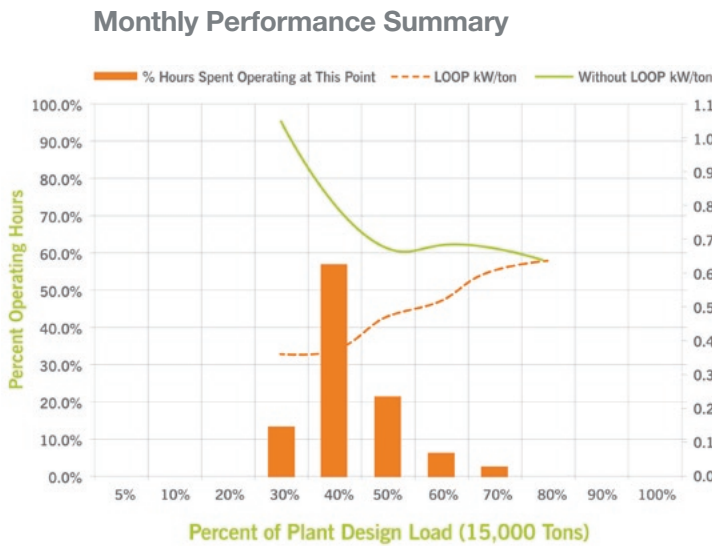
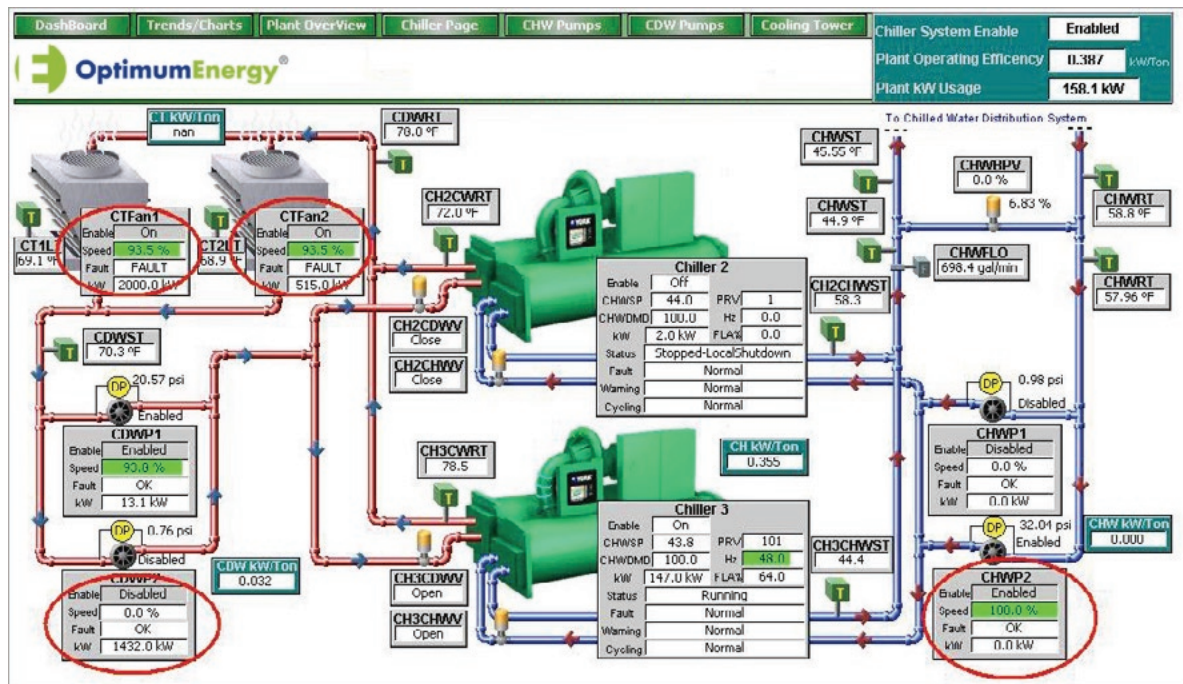

Figure 9: Monthly plant efficiency reports include graphical representation of key operating statistics. This Performance Summary shows that for about 70% of the total run hours, this plant was running between 30% to 40% of design load where the performance ranged from 0.32 to 0.35 kW/ton.

can streamline operations, perform better predictive maintenance and quickly detect, diagnose and correct system faults that are unavoidable in highly complex HVAC systems. In effect, the new standard is a continuous, real-time commissioning process that eliminates drift and makes conventional commissioning obsolete.

The use of proven, reliable networked software solutions such as OptimumHVAC – which combines demand-based energy reduction software with an ongoing online energy management solution – is the only way to achieve Ultra High Performance HVAC, and guarantee that intended payback and long-term value are realized. □

Case Study: Detecting Hidden Faults with OptimumMVM



OptimumMVM Case Study: In this example, anomalies in the operation of the plant's chilled water pumps and tower fans were immediately identifiable in the Plant Overview screen of OptimumMVM.

Optimum Energy engineers were alerted to a problem with the chilled water pumps and tower fans in the centrifugal chiller plant of a 315,000 sq. ft. commercial office building in Northern California. The pumps and fans appeared to be running, but the operating data coming from the building automation system (BAS) was inconsistent with normal operations. Based on the data, Optimum Energy believed that the variable frequency drives (VFDs) were not communicating correctly with the BAS.

As a result of Optimum Energy alerting the building operators of the anomalies, the controls contractor was called in to investigate. With data in hand, the controls contractor was able to rapidly

hone in on the system fault and troubleshoot the communication links between the VFDs and the BAS. It was quickly discovered that an end-of-line resistor had been inadvertently removed, which caused the communication failures between the VFDs and the BAS.

Without access to operating data via OptimumMVM, the anomalies would not have been apparent. The chilled water pumps and tower fans likely would have continued to operate under default settings until the system could no longer keep up with building load demands. As a result, the potential energy reductions and cost savings from using OptimumHVAC would not have been achieved. □

Case Study: Optimizing Equipment Operation with OptimumMVM

Humidity control is of vital importance for museums charged with protecting ancient artifacts. When a museum in Southern California started experiencing a periodic rise in humidity that was putting an important display in jeopardy, building operators contacted Optimum Energy to help diagnose the problem.

Using the charting capabilities of OptimumMVM, humidity levels, chiller state and chilled water temperature points were compared. The analysis revealed a correlation between the staging on/off of a chiller compressor and the increase in the chilled water supply temperatures and humidity levels. Data showed that at each on/off event, the chilled water supply temperature would exceed specifications for at least 15 minutes, and it would

take another 30 minutes to complete the cycle to bring the chilled water supply back down to proper temperature. While a 30 minute cycle time would not cause an issue with comfort cooling, in sensitive environments, such as the museum, the impact to humidity levels was critically important.

As a result of the analysis, the museum contacted the chiller manufacturer and requested adjustments to the chiller to shorten the cycle time. As a result, they were able to maintain more consistent humidity levels. By being able to demonstrate the correlation between chiller events and the rise in chilled water supply temperatures and humidity, the museum was able to have the required chiller adjustments made quickly. □

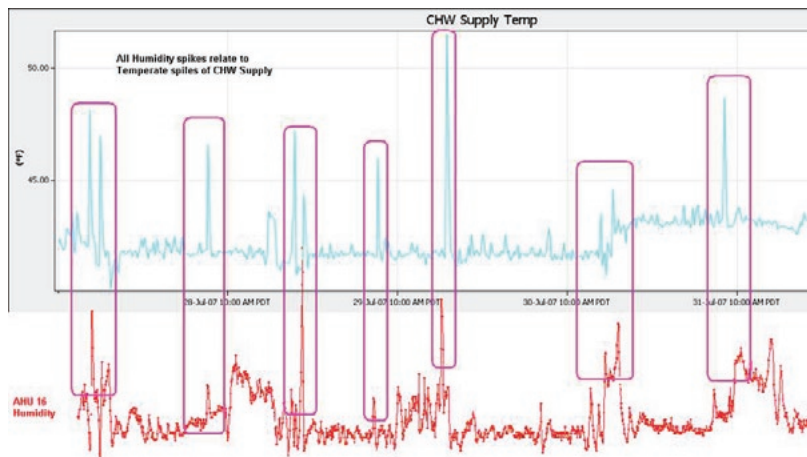
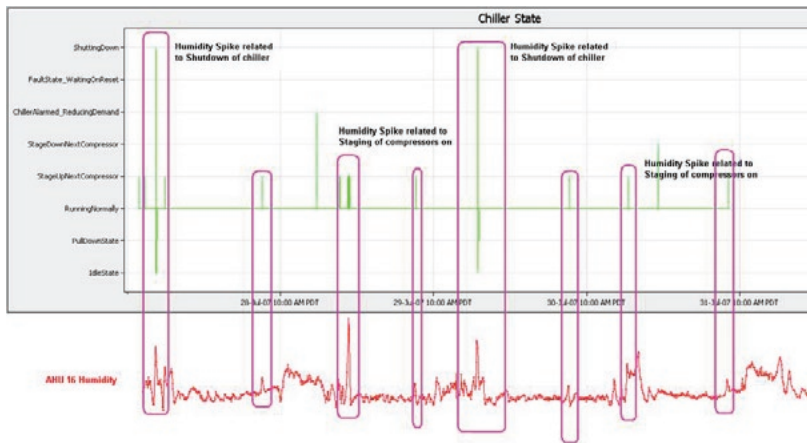

OptimumMVM Case Study: In this example, custom charts were created to correlate the on/off staging of the chiller and the chilled water supply temperature with humidity levels. Using these charts, the chain of events that caused the periodic rise in humidity levels was easily diagnosed.

About: Optimum Energy

Optimum Energy's Ultra High Performance HVAC solutions are proven to permanently reduce energy consumption in commercial building HVAC systems and district cooling by up to 60%. Compatible with all Building Automation Systems, OptimumHVAC software improves operating efficiencies in centrifugal chilled water plants and variable air volume air handling systems through the use of patented relational-control strategies. OptimumHVAC also enables persistent reductions by utilizing the Web to give building operators the continuous operating data and analysis tools they need to detect, diagnose and correct system faults as they occur. This two pronged approach that incorporates demand-based energy reduction

with an ongoing energy management solution gives OptimumHVAC customers reliable and consistent energy reductions that are only possible with an integrated solution.

Today, Optimum Energy's scalable solutions are employed in a wide range of facilities, including: commercial high rise office towers, schools and universities, federal and state government facilities, data centers, labs, medical facilities, airports, hotels, casinos and shopping centers.

Learn more about Optimum Energy at www.optimumenergyhvac.com



Optimum Energy LLC

411 First Avenue South | Suite 620
Seattle, WA 98104

T 877.809.HVAC (4822)

F 888.221.0568

e-mail info@optimumenergyHVAC.com

OptimumEnergyHVAC.com